

MODULUS

Spread Spectrum Comm Module 1120 with UPS

Modulus Spread Spectrum Communications modules have built-in 900MHz Spread Spectrum radios for secure data exchange over a license-free wireless network. They also support **wired** communications with Modbus, DF1, Ethernet IP, SDX, MQTT and SDI-12.

Spread Spectrum Communications modules have built-in analog and digital I/O for tank level and process monitoring, and pump control applications such as wells, lift stations and booster pumping stations. The modules may be ordered with analog inputs supporting either mA, voltage or resistance/temperature measurement. In addition, they have five discrete inputs (one high-speed and four optically isolated), three discrete outputs, and two analog outputs.

Modulus Spread Spectrum Communications modules have two serial ports (bus port plus one general purpose port). The bus port may also be used for general purpose RS-485 communications when not bussed with other Modulus I/O modules.

Modulus Spread Spectrum Communications modules with UPS have a built-in battery backup function, with charger, to keep them running from an external sealed lead-acid (SLA) battery when main power is lost. The module will also supply backup power to any other modules on the bus.

STANDALONE OPERATION

Modulus Spread Spectrum Communications modules can serve as stand-alone devices with SCADA communications, local and web human machine interfaces (HMIs), historical trending and data logging, alarming, reporting, and programmable logic.

COMMUNICATIONS

Modulus Spread Spectrum Communications modules have a built-in 1W 900MHz Spread Spectrum radio, either Xtend compatible for adding to older systems, or SX for new designs. They also have an Ethernet port and two serial ports to communicate with Modbus devices and Allen Bradley PLCs. They can serve as communications concentrators or master controllers, as well as providing web and data access to any other Modulus modules on the high-speed bus. They support Ethernet to Serial bridging, and routing through Ethernet ports in other Modulus modules on the bus.

GRAPHICAL, MOBILE, AND LOCAL HMIs

Configurable graphical and mobile device web interfaces, including the tools and libraries to build custom screens, are built in. The front panel display can also be customized to show live process values and states, and make setting changes.

HISTORICAL TRENDING AND EVENT LOGGING

Modulus Spread Spectrum Communications modules have an internal flash disk, as well as a micro SD memory card slot to record over 100 years of data! Use built-in web tools to retrieve and display historical trend and event data and extract it as spreadsheet files.

REPORTING

Reports with custom graphics and logos can be created in minutes, showing live values, totals, trend/event data, alarm summaries, etc. They can be called up on demand, or sent out automatically.



Digi 1/4W Spread Spectrum Radio Module
8x-5142 1DI/PI, 4DI, 3DO, 2AI (20mA)
8x-5242 1DI/PI, 4DI, 3DO, 2AI (V)
8x-5342 1DI/PI, 4DI, 3DO, 2AI (ohms)

Digi Xtend 1W Spread Spectrum Radio Module
8x-5143 1DI/PI, 4DI, 3DO, 2AI (20mA)
8x-5243 1DI/PI, 4DI, 3DO, 2AI (V)
8x-5343 1DI/PI, 4DI, 3DO, 2AI (ohms)

Digi SX 1W Spread Spectrum Radio Module
8x-5144 1DI/PI, 4DI, 3DO, 2AI (20mA)
8x-5244 1DI/PI, 4DI, 3DO, 2AI (V)
8x-5344 1DI/PI, 4DI, 3DO, 2AI (ohms)

Optional Field Wiring Panel

Modulus Spread Spectrum Communications Modules—UPS

- 1 ETHERNET PORT
- 1 900MHZ SPREAD SPECTRUM RADIO, CHOICE OF 1/4W OR 1W
- 2 SERIAL PORTS (BUS PORT PLUS A GENERAL PURPOSE PORT)
- 1 DISCRETE/HIGH-SPEED PULSE INPUT
- 4 DISCRETE INPUTS (OPTICALLY ISOLATED)
- 3 DISCRETE OUTPUTS (PROTECTED FET)
- 2 ANALOG INPUTS (8X-514X-mA, 8X-524X-V, 8X-534X-ohms/temp)
- 1 UPS (BACKUP POWER SWITCHING AND BATTERY CHARGER)

ALARMING

A Modulus Spread Spectrum Communications module can manage alarm conditions on any of its local inputs, as well as over 500 conditions monitored by communications with other devices. Alarms conditions can be displayed locally and annunciated with its discrete output, as well as text message and e-mail alerts over the Internet via its Ethernet port. The module maintains a journal spreadsheet file of when alarms occurred, when they were acknowledged, by whom, and when the alarm conditions cleared.

PROGRAMMABLE LOGIC

Modulus Spread Spectrum Communications modules support programmable logic written in ladder logic, function block and text languages; all with 32-bit integer and floating point math. Programmable logic can supplement the built-in functions of the module.

PID & PUMP CONTROL

Modulus Spread Spectrum Communications modules have a quad PID controller and a triplex pump controller (float or level control) with error detection and alarming. The Spread Spectrum Communications Module is an ideal solution for SCADA operation of wells, lift stations, and booster pump stations.

REDUNDANCY

Modulus Spread Spectrum Communications modules support redundancy for enhanced reliability. If a module goes off-line, a designated backup can take over automatically.

Modulus Spread Spectrum Communications Module with UPS - Type 1120 - Specifications

FIELD I/O

| | | |
|--------------------------|---|---|
| Discrete Inputs: | 1 | High-speed, non-isolated DC or contact closure, DC to 20KHz maximum |
| Input Range: | | Contact closure/open collector driver to ground, or 0 to 30Vdc (ON=<1.5V, OFF > 2.5V) |
| Input Current: | | Approximately 0.5mA (internal current source) |
| Filtering: | | Individually configurable: 5Hz, 10Hz, 20Hz, 50Hz, 100Hz, 500Hz, 1KHz, 2KHz, 5KHz, 10KHz+ |
| | 4 | Optically Isolated, bipolar (AC/DC, not polarity sensitive) |
| Input Range: | | 0 to 30V (OFF < 6V, ON>9V) |
| Input Current: | | 1.2mA @ 12V, 3mA @ 24V |
| Filtering: | | Individually configurable: 20Hz or 100Hz |
| Discrete Outputs: | 3 | Solid-state Protected FET high-side drivers (switch to input power when ON) |
| Output Rating: | | 30Vdc, 2A maximum, current limited to approximately 2.25A. |
| Analog Inputs: | 2 | 16-bit, Delta Sigma, individually software configurable ranges |
| Input Range: | | <ul style="list-style-type: none">• [8X-514X] 20mA (minimum input for full accuracy is 0.5mA)• [8X-524X] 5V, +/-5V, 10V, +/-10V, 30V• [8X-534X] 50K ohms, temperature using 2.2K, 10K (type II, III and w/11.K shunt) thermistors |
| Analog Outputs: | 2 | 12-bit |
| Output Ranges: | | <ul style="list-style-type: none">• 0- 20mA, 4-20mA |

COMMUNICATIONS

| | | |
|------------------------|---|---|
| Ethernet: | 1 | 10/100mb/s (10/100 Base-T) |
| SCADA Protocols | | Modbus TCP & UDP (master/slave), Ethernet IP (master/slave PLC5 & SLC5/05 emulation), SDX (AES-128 Encryption), MQTT, Ethernet to Serial bridging |
| Internet Protocols | | HTTP (server), FTP (server & client), E-mail (SMTP and POP3), ICMP (ping; server & client), NTP (client), DHCP (server & client), DNS, DDNS |
| Wireless: | 1 | 900MHz Frequency Hopping Spread Spectrum Spread Spectrum radio |
| | | 1/4W (24dBm): Digi Xtend [8x-5x42], 1W (30dBm): Digi Xtend [8x-5x43] or SX [8x-5x44] |
| | | [8x-5x42 and 8x-5x43] -110 dBm sensitivity @ 9.6kbps [8x-5x44] -113 dBm sensitivity @ 9.6kbps |
| SCADA Protocols | | Modbus RTU (master/slave), DF1 (slave), SDX (AES-128 Encryption) |
| Serial: | 1 | RS-232, RS-485, RS-422, SDI-12 (for general purpose communications) |
| | 1 | RS-485 Bus port (this port is available for general purpose communications if not used for high-speed bus communications with other modules) |
| Baud Rates (all ports) | | 115K, 38.4K, 19.2K, 9600, 4800, 2400, 1200 baud. |
| Protocols | | Modbus RTU (master/slave), DF1 (slave), SDX (AES-128 Encryption), SDI-12 (general purpose port only) |

HMIs

| | |
|-------------------|--|
| Local: | 128x32 graphical, wide temperature range yellow OLED and single pushbutton |
| Graphical: | Web based, graphic library included. Compatible with most browsers, including Internet Explorer, Firefox, Chrome, Safari, Android |
| Mobile: | Web based, text only, up to 50 registers. Compatible with most browsers, including Internet Explorer, Firefox, Chrome, Safari, Android |

PROGRAMMING

| | |
|-------------------|--|
| Languages: | Ladder Logic, Function Block, Text—built-in web based graphical and text editor and debugger |
| Capacity: | 64KB logic, 2MB source code, 32-bit integer and floating point math |

STORAGE

| | |
|-----------------------------|---|
| Registers: | 504 Numeric registers, 504 Boolean registers |
| Internal Flash disk: | 32MB |
| Removable disk: | Micro SD Card (up to 256GB, supplied by customer) |

CLOCK

| | |
|-------------------------|---|
| Real Time Clock: | Temperature compensated with lithium battery backup power |
| Stability | +/- 3ppm from -30°C to 70°C |

UPS BATTERY BACKUP

| | |
|--------------------------------|---|
| Battery Type Supported: | Sealed Lead-acid (SLA) - Purchase separately; 7AH (p/n 90-9007), 12AH (p/n 90-9012) |
| Charging Current | 0.5A |
| Backup power to other modules | 2A via Modulus bus |

GENERAL

| | |
|----------------------------------|---|
| Input Power: | 10Vdc to 30Vdc |
| Power Consumption | |
| Not using Ethernet | 18mA @ 12Vdc / 13mA @ 24Vdc (Ethernet power saver enabled) |
| Using Ethernet | 78mA @ 12Vdc / 43mA @ 24Vdc |
| Radio Transmitting | [81-5x42] Add 100mA @ 12Vdc 50mA @ 24Vdc in short transmit bursts [81-5x43, 8x-5x44] Add 320mA @ 12Vdc 160mA @ 24Vdc in short transmit bursts Add up to 600mA @15Vdc / 300mA @24Vdc |
| Battery Charging | [81-5x4x] screw terminal blocks [82-5x4x] lever terminal blocks, 3.5mm, 22 to 14GA wires |
| Field Wiring Termination: | |
| Antenna Connector: | RP-SMA female (male pin center conductor) |
| Temperature: | -40°C to 70°C (operating), -40°C to 85°C (storage) |
| Humidity: | <95% RH (non-condensing) |
| Enclosure: | Polyamide, light gray (RAL 7035) |
| Mounting: | 35mm DIN rail with bus connector block |



Specifications subject to change without notice. Consult factory to ensure that you are working with current information.

Modulus Spread Spectrum Communications Module with UPS - Type 1120—Antenna Wiring

DIMENSIONS and CONNECTIONS

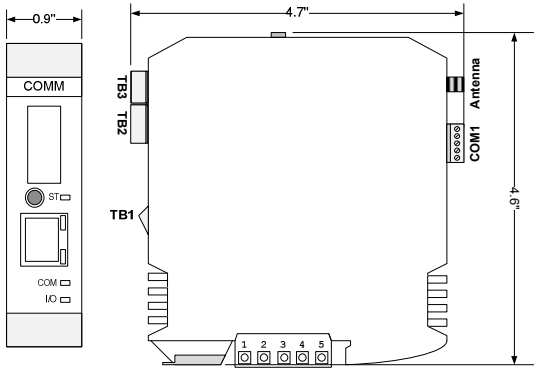

| Terminal | Function |
|----------|----------|
| 1 | -485 |
| 2 | +485 |
| 3 | RESET# |
| 4 | GND |
| 5 | +V |

| Terminals | TB1 | TB2 | TB3 |
|-----------|-----|------|-----|
| 1 | DI1 | DO2 | DI2 |
| 2 | AI1 | DO3 | DI3 |
| 3 | AI2 | BAT+ | DI4 |
| 4 | DO1 | BAT- | DI5 |
| 5 | GND | | DIC |

General Purpose Communications Port COM1 (modes are software configured)

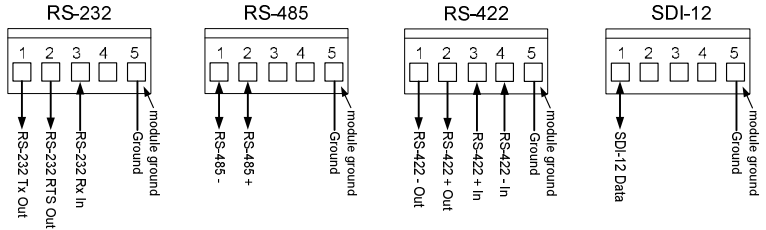

Typical COM1 RS-232 Wiring to Modem/Radio

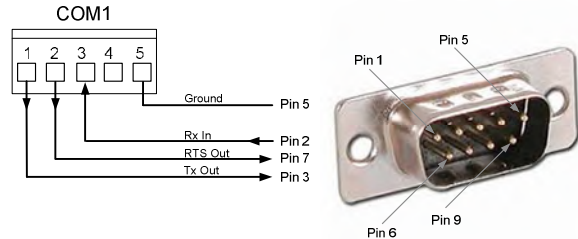

Yagi

Omni

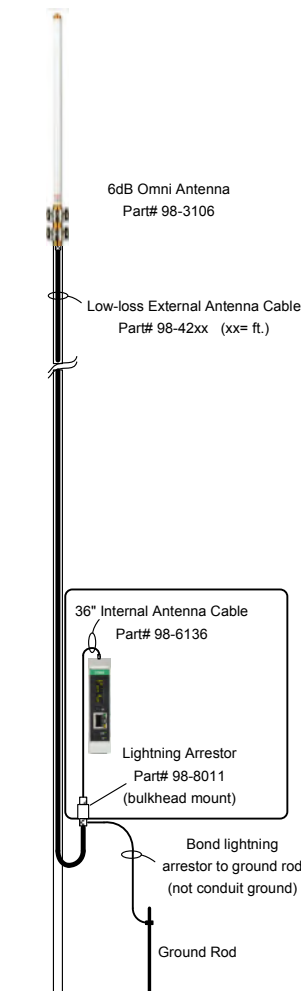
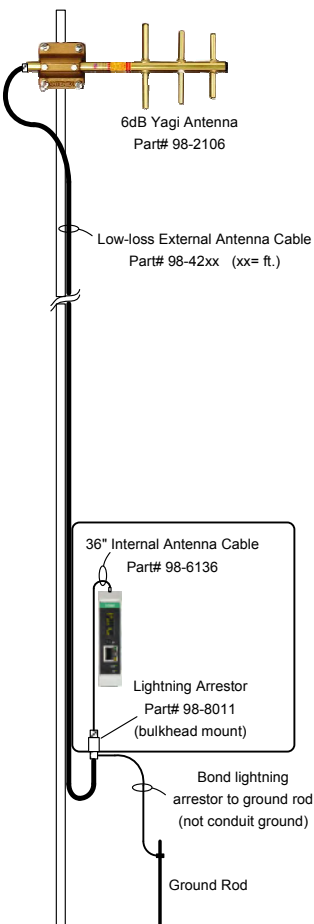

Antenna System Options

Spread Spectrum radio systems use antennas mounted external to the controller. The type of antenna used depends on both the distance to be covered and the terrain between any two sites that are to be linked together. The selection of antennas, mounting height above grade, cable types, etc. should be determined by use of a radio path study to ensure reliable communications. There are three types of antennas typically used:

- ◆ "Salt Shaker" style Omni-directional for moderate distances
- ◆ 6dB Omni-directional for best performance at a Master or repeater site
- ◆ 6dB Yagi directional for best noise rejection and signal focus at remote sites

"Salt Shaker" Style Omnidirectional for Medium Distance Communications

A "Salt Shaker" style antenna is the lowest cost, and easiest type to deploy in the field. It can be mounted on the top of the equipment panel and works well for moderate communications distance. Since it is omni-directional, there is no aiming or alignment required in the field. The antenna part number is **98-3103**, and connects to the communications module with a short internal antenna cable (part number **98-6536**).



"salt shaker" antenna

Antenna Components for Maximum Communications Distances

Using elevated higher gain antennas can significantly improve the performance and reliable operating distance of a radio system. Since elevating the antennas will also increase the installation and maintenance cost of the system, you should always have a radio path study done to select the antenna components and mounting arrangements. Omni-directional antennas do not need to be aimed while Yagi directional antennas will provide better off-axis noise rejection. For either type of antenna system, a lightning arrestor is generally recommended since by being elevated, the antennas become a better "target" for a lightning strike. Use a dedicated grounding rod and bonding as shown for the lightning arrestor.

Antenna System BOM:

| | |
|----------------|---|
| 98-6536 | 36" Internal Antenna Cable |
| 98-8011 | Lightning Arrestor |
| 98-42xx | Low-loss Antenna Cable (xx= length in feet) |
| 98-2106 | Spread Spectrum Yagi Directional Antenna or |
| 98-3106 | Spread Spectrum 6dB Omni-directional Antenna |
| 98-9002 | Weatherproofing Kit (for external antennal connections) |

Modulus Spread Spectrum Communications Module with UPS - Type 1120 - Field Device Wiring

! Refer to the installation manual for additional installation details and precautions.

Discrete Input DI1, Discrete Output DO1 & Analog Inputs —TB1

The field wiring may be connected directly to the TB1 terminal block, or through a field Wiring Panel as shown in the diagrams below. All discrete inputs/outputs and analog inputs are referenced to the ground terminal (5). This terminal is connected internally to the power supply ground.

The Discrete Input accepts a contact closure or open-collector ("NPN" style) input signal. An external pull-up resistor is not required.

The Discrete Output sources current by switching the module input power to the output terminal.

The 8x-514x models have analog Inputs that accept 20mA current signals. Loop powered (Figure A) and self-powered (Figure C) devices are supported. In power conserving applications, the analog sensors may be powered from the Discrete Output (Figure B), configured to switch power to the sensors only when needed to take an analog reading (with configurable "warmup" time).

The 8x-524x models have analog Inputs that support voltage sensors (+/-5v, +/-10v and 30v) while the 8x-534x models support resistance sensors including thermistor type temperature sensors. The wiring for these sensors is shown in Figure D below.

Note that for loop powered devices, model 82-01xx Field Wiring Panels should be used. For self-powered devices, either model 82-00xx or 82-01xx Field Wiring Panels may be used.

8x-514x (20mA Analog Inputs)

FIGURE A

20mA Loop Powered Sensors
External Loop Supply

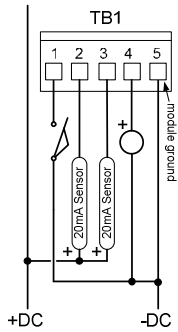

FIGURE B

Sensor Power from
Discrete Output

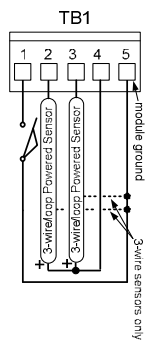
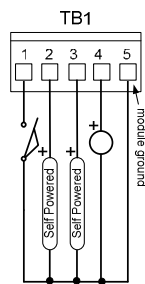

FIGURE C

Self-powered
20mA Sensors



**82-01xx Field
Wiring Panel**

**82-01xx Field
Wiring Panel**

**82-00xx or 82-01xx
Field Wiring Panel**

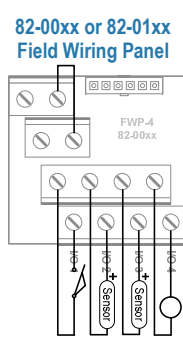
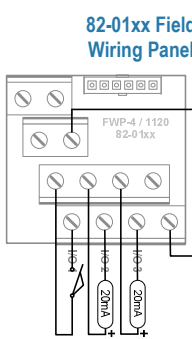
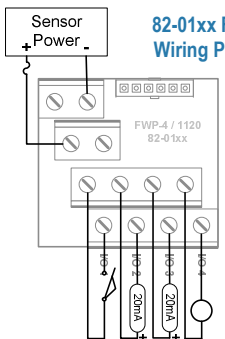

8x-524x (Voltage) and 8x-534x (Resistance/Temperature) Analog Inputs

FIGURE D

Voltage and Resistance
Sensor Wiring

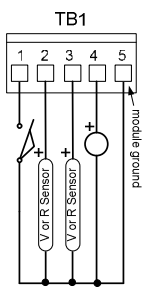

Note:
Resistance sensors
do not have a polarity

**82-00xx or 82-01xx
Field Wiring Panel**

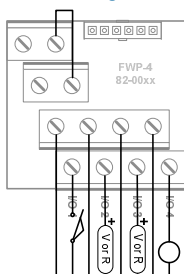

Discrete Outputs DO2 and DO3, Battery—TB2

UPS Comm modules add two FET discrete outputs and battery backup functionality to the base module. The field wiring to these outputs may be connected directly to the TB2 terminal block, or through an 82-02xx Field Wiring Panel as shown in the diagrams below. The cable for the field wiring panel is terminated with a 4-position terminal block plug that plugs into the module, and a separate ground wire that is connected back to the power ground (usually at the base terminal block on the DIN rail).

The Discrete Outputs source current ("PNP" style) by switching the module input power to the output terminals.

A 7AH or 12AH Sealed Lead Acid (SLA) battery should be connected as shown. Do not connect the battery directly to the modules system ground connection.

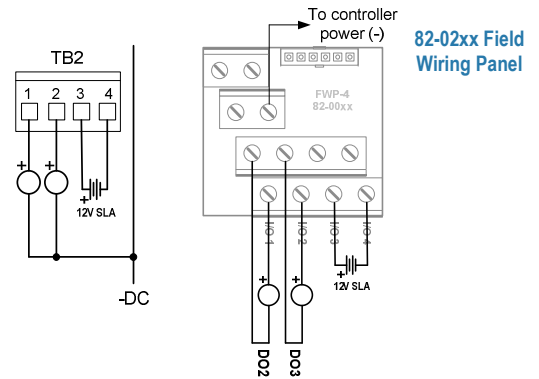

Discrete Inputs DI2 to DI5 —TB3

UPS Comm modules have four optically isolated discrete inputs. The field wiring to these inputs may be connected directly to the TB3 terminal block, or through a Field Wiring Panel as shown in the diagrams below. The common for the discrete inputs is shared among the four inputs but isolated from the rest of the module.

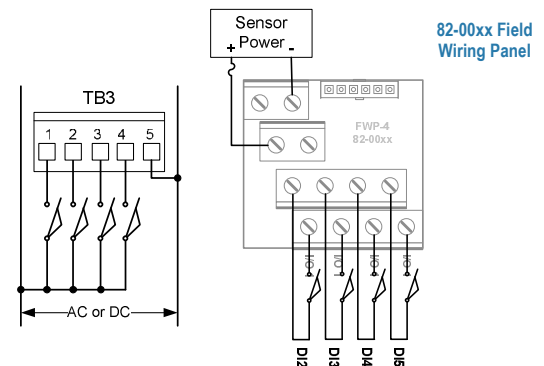

Sensor power may be AC or DC of either polarity. It can be the same source as the module input power.



Industrial Control Links, Inc.
Roseville, CA 530.888.1800