

# MODULUS

## Serial Communications Module 2110

Modulus Serial Communications modules provide up to three serial ports (bus port plus two general purpose ports) for interfacing with external radios, modems and intelligent control and monitoring devices such as variable frequency drives and power monitors. The bus port may also be used for general purpose RS-485 communications when not bussed with other Modulus I/O. Each port operates independently as a master or slave using industry-standard protocols such as Modbus, DF1, SDX (AES-128 encryption), and SDI-12. The modules also have an Ethernet port supporting Modbus, Ethernet IP, MQTT, and SDX protocols, as well as Ethernet-Serial bridging and Ethernet Routing.

The Serial Communications modules have built-in analog and digital I/O for tank level and process monitoring, and pump control applications such as wells, lift stations and booster pumping stations. The modules have an analog input supporting both mA and voltage measurement. In addition, they have six discrete inputs (two high-speed and four optically isolated), three discrete outputs, and two analog outputs.

### STANDALONE OPERATION

Modulus Serial Communications modules can serve as standalone devices with SCADA communications, local and web human machine interfaces (HMIs), historical trending and data logging, alarming, reporting, and programmable logic.

### COMMUNICATIONS

Modulus Serial Communications modules have an Ethernet port and up to three serial ports to communicate with Modbus devices and Allen Bradley PLCs. They can serve as communications concentrators or master controllers, as well as providing web and data access to any other Modulus modules on the high-speed bus. They support Ethernet to Serial bridging, and routing through Ethernet ports in other Modulus modules on the bus.

### GRAPHICAL, MOBILE, AND LOCAL HMIs

Configurable graphical and mobile device web interfaces, including the tools and libraries to build custom screens, are built in. The front panel display can also be customized to show live process values and states, and make setting changes.

### HISTORICAL TRENDING AND EVENT LOGGING

Modulus Serial Communications modules have an internal flash disk, as well as a micro SD memory card slot to record over 100 years of data! Use built-in web tools to retrieve and display historical trend and event data and extract it as spreadsheet files.

### REPORTING

Reports with custom graphics and logos can be created in minutes, showing live values, totals, trend/event data, alarm summaries, etc. They can be called up on demand, or sent out automatically.



Serial Communications Module  
8x-5000 2DI/PI, 1DO, 1AI (20mA/V)



Optional Field Wiring Panel

### Modulus Serial Communications Module

- 1 **ETHERNET PORT**
- 3 **SERIAL PORTS (BUS PORT PLUS 2 GENERAL PURPOSE PORTS)**
- 2 **DISCRETE/HIGH-SPEED PULSE INPUTS**
- 1 **DISCRETE OUTPUT (PROTECTED FET)**
- 1 **ANALOG INPUT (mA, V)**

### ALARMING

A Modulus Serial Communications module can manage alarm conditions on any of its local inputs, as well as over 500 conditions monitored by communications with other devices. Alarms conditions can be displayed locally and annunciated with its discrete output, as well as text message and e-mail alerts over the Internet via its Ethernet port. The module maintains a journal spreadsheet file of when alarms occurred, when they were acknowledged, by whom, and when the alarm conditions cleared.

### PROGRAMMABLE LOGIC

Modulus Serial Communications modules support programmable logic written in ladder logic, function block and text languages; all with 32-bit integer and floating point math. Programmable logic can supplement the built-in functions of the module.

### PID & PUMP CONTROL

Modulus Serial Communications modules have a quad PID controller and a triplex pump controller (float or level control) with error detection and alarming. The Serial Communications Module is an ideal solution for SCADA operation of wells, lift stations, and booster pump stations.

### REDUNDANCY

Modulus Serial Communications modules support redundancy for enhanced reliability. If a module goes off-line, a designated backup can take over automatically.

# Modulus Serial Communications Module - Type 2110 - Specifications

## FIELD I/O

<b>Discrete Inputs:</b>	2	High-speed, non-isolated DC or contact closure, DC to 20KHz maximum
Input Range:		Contact closure/open collector driver to ground, or 0 to 30Vdc (ON=<1.5V, OFF > 2.5V)
Input Current:		Approximately 0.5mA (internal current source)
Filtering		Individually configurable: 5Hz, 10Hz, 20Hz, 50Hz, 100Hz, 500Hz, 1KHz, 2KHz, 5KHz, 10KHz+
<b>Discrete Outputs:</b>	1	Solid-state Protected FET high-side drivers (switch to input power when ON)
Output Rating:		30Vdc, 2A maximum, current limited to approximately 2.25A.
<b>Analog Inputs:</b>	1	16-bit, Delta Sigma, individually software configurable ranges
Input Range:		• 20mA (minimum input for full accuracy is 0.5mA) • 5V, +/-5V, 10V, +/-10V, 30V

## COMMUNICATIONS

<b>Ethernet:</b>	1	10/100mb/s (10/100 Base-T)
SCADA Protocols		Modbus TCP & UDP (master/slave), Ethernet IP (master/slave PLC5 & SLC5/05 emulation), SDX (AES-128 Encryption), MQTT, Ethernet to Serial bridging
Internet Protocols		HTTP (server), FTP (server & client), E-mail (SMTP and POP3), ICMP (ping; server & client), NTP (client), DHCP (server & client), DNS, DDNS
<b>Serial:</b>	1	RS-232, RS-485, RS-422, SDI-12 (COM1 - general purpose communications port.)
	1	RS-232, RS-485, RS-422 (COM2 - general purpose communications port.)
	1	RS-485 Bus port (this port is available for general purpose communications if not used for high-speed bus communications with other modules)
Baud Rates (all ports)		115K, 38.4K, 19.2K, 9600, 4800, 2400, 1200 baud.
Protocols		Modbus RTU (master/slave), DF1 (slave), SDX (AES-128 Encryption), SDI-12 (general purpose port only)

## HMIs

<b>Local:</b>	128x32 graphical, wide temperature range yellow OLED and single pushbutton
<b>Graphical:</b>	Web based, graphic library included. Compatible with most browsers, including Internet Explorer, Firefox, Chrome, Safari, Android
<b>Mobile:</b>	Web based, text only, up to 50 registers. Compatible with most browsers, including Internet Explorer, Firefox, Chrome, Safari, Android

## PROGRAMMING

<b>Languages:</b>	Ladder Logic, Function Block, Text—built-in web based graphical and text editor and debugger
<b>Capacity:</b>	64KB logic, 2MB source code, 32-bit integer and floating point math

## STORAGE

<b>Registers:</b>	504 Numeric registers, 504 Boolean registers
<b>Internal Flash disk:</b>	32MB
<b>Removable disk:</b>	Micro SD Card (up to 256GB, supplied by customer)

## CLOCK

<b>Real Time Clock:</b>	Temperature compensated with lithium battery backup power
Stability	+/- 3ppm from -30°C to 70°C

## GENERAL

<b>Input Power:</b>	10Vdc to 30Vdc
<b>Power Consumption</b>	
Not using Ethernet	18mA @ 12Vdc / 13mA @ 24Vdc (Ethernet power saver enabled)
Using Ethernet	78mA @ 12Vdc / 43mA @ 24Vdc
<b>Field Wiring Termination:</b>	[81-5000] screw terminal blocks [82-5000] lever terminal blocks, 3.5mm, 22 to 14GA wires
<b>Temperature:</b>	-40°C to 70°C (operating), -40°C to 85°C (storage)
<b>Humidity:</b>	<95% RH (non-condensing)
<b>Enclosure:</b>	Polyamide, light gray (RAL 7035)
<b>Mounting:</b>	35mm DIN rail with bus connector block



# Modulus Serial Communications Module - Type 2110—Communications Port Wiring

## DIMENSIONS and CONNECTIONS

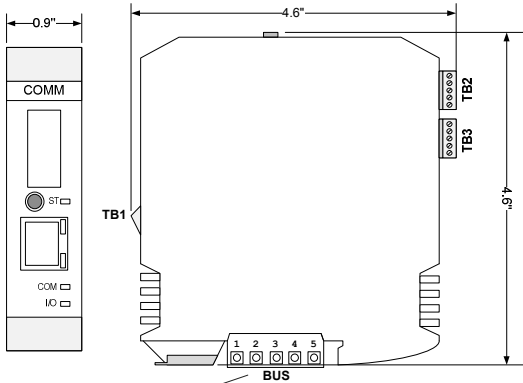

Terminal	Function
1	-485
2	+485
3	RESET#
4	GND
5	+V

Terminals	TB1
1	DI1
2	DI2
3	AI1
4	DO1
5	GND

## General Purpose Communications Port COM1 (modes are software configured)

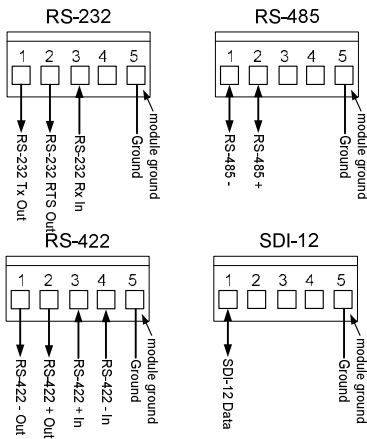

## General Purpose Communications Port COM2 (modes are software configured)

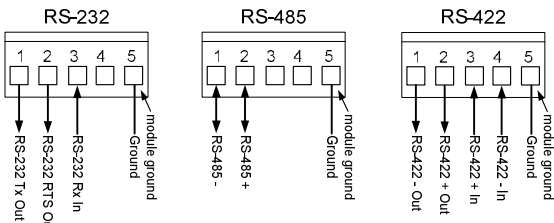

## Typical COM1 and COM2 RS-232 Wiring to Modem/

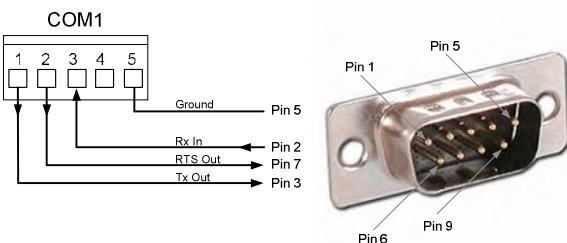

**!** Refer to the installation manual for additional installation details and precautions.

## Discrete Inputs DI1 & DI2, Discrete Output DO1 & Analog Input AI1 - TB1

The field wiring may be connected directly to the TB1 terminal block, or through a field Wiring Panel as shown in the diagrams below. All discrete inputs/outputs and the analog input are referenced to the ground terminal (5). This terminal is connected internally to the power supply ground.

The Discrete Inputs accept contact closures or open-collector ("NPN" style) input signals. External pull-up resistors are not required.

The Discrete Output sources current by switching the module input power to the output terminal.

The analog Input accepts 20mA current or voltage (+/-5v, +/-10v and 30v) signals. The mode is software selectable. Sensors can be either loop powered (Figure A) or self-powered (Figure C). In power conserving applications, the analog sensor may be powered from the Discrete Output (Figure B), configured to switch power to the sensor only when needed to take an analog reading (with configurable "warmup" time (a 20mA loop powered sensor is shown below, but a voltage sensor can also be used by switching its power).

Note that for all configurations, the model 82-00xx Field Wiring Panel is used.

**FIGURE A**  
20mA Loop Powered Sensors  
External Loop Supply

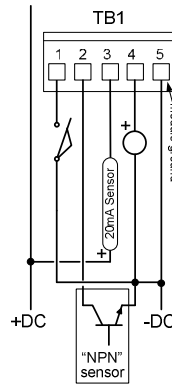

82-00xx Field  
Wiring Panel

**FIGURE B**  
Analog Sensor Power  
from Discrete Output  
(power saver)

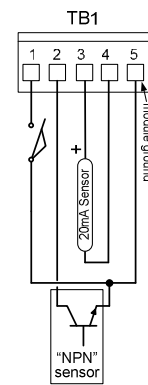

82-00xx Field  
Wiring Panel

**FIGURE C**  
Self-powered  
Sensors

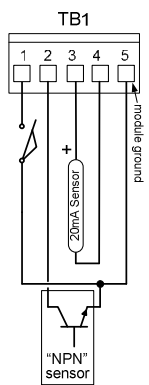

82-00xx Field  
Wiring Panel

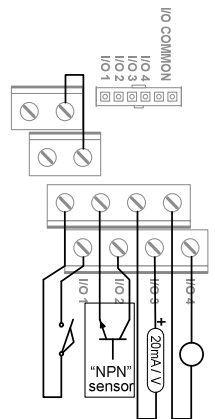
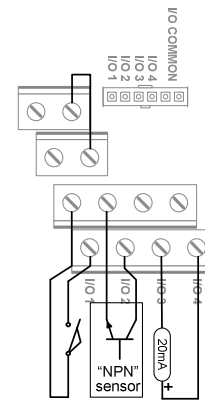
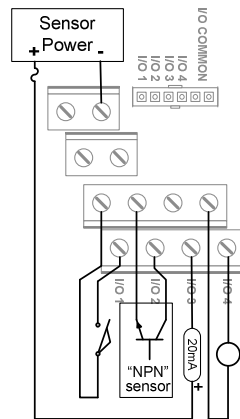



Industrial Control Links, Inc.  
Roseville, CA 530.888.1800