

MODULUS

Discrete Input/Output Modules 1608

Modulus Discrete Input/Output (DIDO) modules extend the I/O capacity of Modulus SCADA controllers, as well as the many 3rd party devices. The modules have an Ethernet port supporting Modbus, Ethernet IP, MQTT, and SDX protocols, as well as Ethernet-Serial bridging and Ethernet Routing. Their bus port may be used for general purpose RS-485 communications (when not bussed with other Modulus I/O), operating as a master or slave using industry-standard protocols such as Modbus, DF1, SDX (AES-128 encryption), and SDI-12.

DIDO modules are available as 12/24V or 120/240V Discrete Input models. Both AC and DC signals are supported.

Modulus DIDO modules have built-in web pages for configuration, programming, monitoring and manuals. No application software is needed; just a web browser. Custom user documentation can also be loaded into the module, so that drawings, datasheets, etc. are always available for site support and maintenance.

STANDALONE OPERATION

Modulus DIDO modules can serve as standalone devices with SCADA communications, local and web human machine interfaces (HMIs), trending and data logging, alarming, reporting, and programmable logic control.

COMMUNICATIONS

DIDO modules have an Ethernet port and a serial port to communicate directly with Modbus devices, as well as Allen Bradley PLCs. They can serve as communications concentrators or master controllers, as well as providing web and data access to any other Modulus modules on the high-speed bus. They support Ethernet to Serial bridging, and routing through Ethernet ports in other Modulus modules on the bus.

GRAPHICAL, MOBILE, AND LOCAL HMIs

Configurable graphical web and mobile device interfaces are built into DIDO modules. The front panel display can also be customized to show live process values and states, and make setting changes.

HISTORICAL TRENDING AND EVENT LOGGING

DIDO modules have an internal solid state flash disk, as well as a micro SD memory card slot to record over 100 years of data! You can retrieve and display historical data with built-in web tools and extract trend and event data as spreadsheet files.

REPORTING

Reports with custom graphics and logos can be created in minutes, showing live values, totals, trend/event data, alarm summaries, etc. They can be called up on demand, or sent out automatically via an Ethernet/Internet connection.



Discrete Input/Output Modules
8x-1006 16DI, 8DO (12/24V)
8x-1106 16DI, 8DO (120/240V)



Optional Field Wiring Panel

Modulus DIDO Discrete Input / Output Module

- 16 DISCRETE INPUTS (OPTICALLY ISOLATED)
- 8 DISCRETE OUTPUTS (RELAY)
- 1 ETHERNET PORT
- 1 SERIAL PORT

ALARMING

A DIDO module can manage alarm conditions on any of its local inputs, as well as over 500 conditions monitored by communications with other devices. Alarms conditions can be displayed locally and annunciated with a discrete output, as well as by text message and e-mail alerts over the Internet via its Ethernet port. The module maintains a journal spreadsheet file of when alarms occurred, when they were acknowledged, by whom, and when the alarm conditions cleared.

PROGRAMMABLE LOGIC

DIDO modules support programmable logic written in ladder logic, function block and text languages; all with 32-bit integer and floating point math. Programmable logic can supplement the built-in functions of the module.

PID AND PUMP CONTROL

DIDO modules support four Proportional, Integral and Derivative (PID) loops and have a built-in triplex Pump Controller (float or level control with alternation).

REDUNDANCY

DIDO modules support redundancy for enhanced reliability. If a module goes off-line, a designated backup can take over automatically.

Modulus DIDO 1608 Discrete Input/Output Module Specifications

FIELD I/O

Digital Inputs:	16	Optically Isolated, bipolar (AC/DC, not polarity sensitive)
Input Range:	[8x-1006]	0 to 30V (OFF < 6V, ON>9V)
	[81-1106]	0 to 240V (OFF < 60V, ON>90V)
	[82-1106]	0 to 120V (OFF < 60V, ON>90V)
Input Current:	[8x-1006]	1.2mA @ 12V, 3mA @ 24V
	[8x-1106]	1.2mA @ 120V, 3mA @ 240V
Filtering		Inputs 1 through 8: individually selectable—5Hz, 10Hz, 20Hz, 50Hz, 100Hz, 500Hz, 1KHz, 2KHz+
		Inputs 9 through 16: individually selectable—20Hz, 100Hz
Digital Outputs:	8	Relay contacts, Form A (normally open)
Contact Output Rating:		240/277 Vac, 30Vdc, 3A maximum per output (resistive load). Do not exceed 8A on any group of 4 outputs on a terminal block. A snubber diode (DC) or RC snubber (AC) must be used across the relay contacts or load connections for any inductive load.

COMMUNICATIONS

Ethernet:	1	10/100mb/s (10/100 Base-T)
SCADA Protocols		Modbus TCP & UDP (master/slave), Ethernet IP (master/slave PLC5 & SLC5/05 emulation), SDX (AES-128 Encryption), MQTT, Ethernet to Serial bridging
Internet Protocols		HTTP (server), FTP (server & client), ICMP (ping; server and client), NTP (client), DHCP (server & client), DNS, DDNS
Serial:	1	RS-485 (115K, 38.4K, 19.2K, 9600, 4800, 2400, 1200 baud). This port is available if not used for bus communications with other modules.
Protocols		Modbus RTU (master/slave), DF1 (slave), SDX (AES-128 Encryption),

HMIs

Local:	128x32 graphical, wide temperature range yellow OLED and single pushbutton
Graphical:	Web based, graphic library included. Compatible with most browsers, including Internet Explorer, Firefox, Chrome, Safari, Android
Mobile:	Web based, text only, up to 50 registers. Compatible with most browsers, including Internet Explorer, Firefox, Chrome, Safari, Android

PROGRAMMING

Languages:	Ladder Logic, Function Block, Text—built-in web based graphical and text editor and debugger
Capacity:	64KB logic, 2MB source code

STORAGE

Registers:	504 Numeric registers, 504 Boolean registers
Internal Flash disk:	32MB
Removable disk:	Micro SD Card (up to 256GB, supplied by customer)

GENERAL

Input Power:	10Vdc to 30Vdc
Power Consumption (average)	
Not using Ethernet, relays OFF	18mA @ 12Vdc / 13mA @ 24Vdc (Ethernet power saver enabled)
Using Ethernet, relays OFF	78mA @ 12Vdc / 43mA @ 24Vdc
Additional current per relay ON	10mA @ 12Vdc / 5mA @ 24Vdc
Field Wiring Termination:	[81-1x06] screw terminal blocks [82-1x06] lever terminal blocks, 3.5mm, 22 to 14GA wires
Temperature:	-40°C to 70°C (operating), -40°C to 85°C (storage)
Humidity:	<95% RH (non-condensing)
Enclosure:	Polyamide, light gray (RAL 7035)
Mounting:	35mm DIN rail with bus connector block



Modulus DIDO 1608 Discrete Input/Output Module Specifications

DIMENSIONS and WIRING

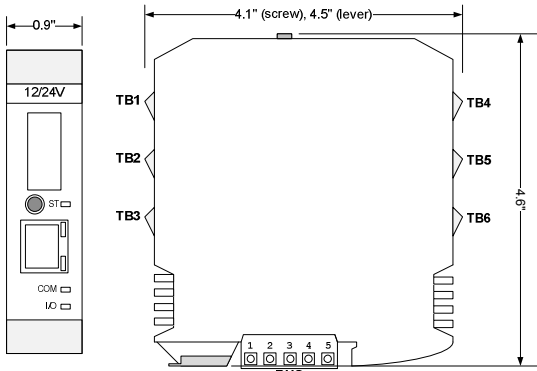

Terminal	Function
1	-485
2	+485
3	RESET#
4	GND
5	+V

Terminal Block	Inputs/Outputs
TB1	DI1 - DI4
TB2	DI5 - DI8
TB3	DI9 - DI12
TB4	DI13 - DI16
TB5	DO1 - DO4
TB6	DO5 - DO8

⚠ Refer to the installation manual for additional installation details and precautions.

OPTICALLY ISOLATED DISCRETE INPUTS

The discrete inputs on a terminal block share a common with only the inputs on that same block and are isolated from all other I/O points. All inputs are bipolar (not polarity sensitive).

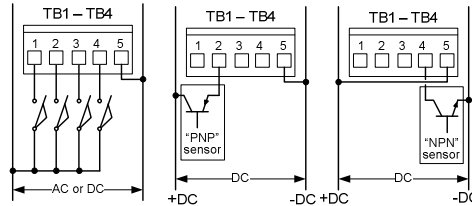

82-00xx Field Wiring Panel

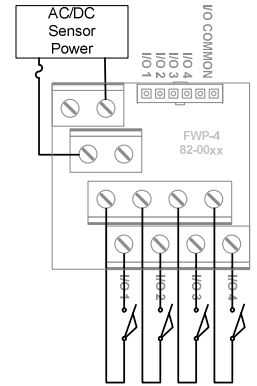

RELAY OUTPUTS

The relay outputs on a terminal block share a common with only the other outputs on that same block and are isolated from all other I/O points.

⚠ A snubber diode (DC) or RC snubber (AC) must be used across the relay contacts or load connections for **any** inductive load.

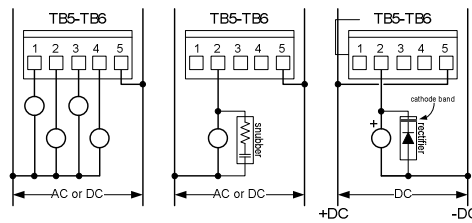

82-00xx Field Wiring Panel

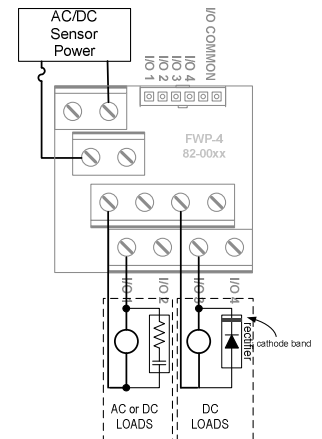



Industrial Control Links, Inc.
Roseville, CA 530.888.1800