

# MODULUS

## Cellular Communications Module 1120 with Audio Out

Modulus Cellular Communications modules have a built-in 4G LTE cellular modem for data exchange over the Internet, alarming/notifications by e-mail and text message, and remote access. They also support **wired** communications with Modbus, DF1, Ethernet IP, SDX, and SDI-12.

The Cellular Communications modules have built-in analog and digital I/O for tank level and process monitoring, and pump control applications such as wells, lift stations and booster pumping stations. The modules may be ordered with analog inputs supporting either mA, voltage or resistance/temperature measurement. In addition, they have five discrete inputs (one high-speed and four optically isolated), and a discrete output.

Modulus Cellular Communications modules have a single serial port (bus port). The bus port may be used for general purpose RS-485 communications when not bussed with other Modulus I/O modules.

These modules have 2 high-quality audio outputs that under program control, can play up to 1000 different MP3 audio segments through a public address or audio radio system. They can also vocalize the values of real-time data in any storage register in multiple common languages.



Verizon Cellular—Audio Out  
**8x-5131** 1DI/PI, 4DI, 1DO, 2AI (20mA)  
**8x-5231** 1DI/PI, 4DI, 1DO, 2AI (V)  
**8x-5331** 1DI/PI, 4DI, 1DO, 2AI (ohms)

AT&T & International Cellular—Audio Out  
**8x-5132** 1DI/PI, 4DI, 1DO, 2AI (20mA)  
**8x-5232** 1DI/PI, 4DI, 1DO, 2AI (V)  
**8x-5332** 1DI/PI, 4DI, 1DO, 2AI (ohms)

Optional Field Wiring Panel

### Modulus Cellular Communications Modules—Audio Out

- 1 ETHERNET PORT
- 1 4G LTE CELLULAR MODEM (VERIZON OR AT&T / INT'L)
- 1 SERIAL RS-485 PORT (BUS PORT)
- 1 DISCRETE/HIGH-SPEED PULSE INPUT
- 4 DISCRETE INPUTS (OPTICALLY ISOLATED)
- 1 DISCRETE OUTPUT (PROTECTED FET)
- 2 ANALOG INPUTS (8X-513X-mA, 8X-523X-V, 8X-533X-ohms/temp)
- 2 AUDIO OUTPUTS (STEREO)

### STANDALONE OPERATION

Modulus Cellular Communications modules can serve as standalone devices with SCADA communications, local and web human machine interfaces (HMIs), historical trending and data logging, alarming, reporting, and programmable logic.

### COMMUNICATIONS

Modulus Cellular Communications modules have a built-in 4G LTE cellular modem that can be ordered to support either Verizon or AT&T / international cellular networks. They also have an Ethernet port and one or two serial ports to communicate with Modbus devices and Allen Bradley PLCs. They can serve as communications concentrators or master controllers, as well as providing web and data access to any other Modulus modules on the high-speed bus. They support Ethernet to Serial bridging, and routing through Ethernet ports in other Modulus modules on the bus.

### GRAPHICAL, MOBILE, AND LOCAL HMIs

Configurable graphical and mobile device web interfaces, including the tools and libraries to build custom screens, are built in. The front panel display can also be customized to show live process values and states, and make setting changes.

### HISTORICAL TRENDING AND EVENT LOGGING

Modulus Cellular Communications modules have an internal flash disk, as well as a micro SD memory card slot to record over 100 years of data! Use built-in web tools to retrieve and display historical trend and event data and extract it as spreadsheet files.

### REPORTING

Reports with custom graphics and logos can be created in minutes, showing live values, totals, trend/event data, alarm summaries, etc. They can be called up on demand, or sent out automatically.

### ALARMING

A Modulus Cellular Communications module can manage alarm conditions on any of its local inputs and other Modulus I/O on the bus, as well as external devices via communications. Alarms conditions can be displayed locally, and annunciated by text message, e-mail, and audible (public address) alerts. Alarms can be acknowledged by text message or e-mail, discrete input, or local HMI button. The module maintains a journal spreadsheet file of when alarms occurred, when they were acknowledged, by whom, and when the alarm conditions clear.

### PROGRAMMABLE LOGIC

Modulus Cellular Communications modules support programmable logic written in ladder logic, function block and text languages; all with 32-bit integer and floating point math. Programmable logic can supplement the built-in functions of the module.

### PID & PUMP CONTROL

Modulus Cellular Communications modules have a quad PID controller and a triplex pump controller (float or level control) with error detection and alarming. The Cellular Communications Module is an ideal solution for SCADA operation of wells, lift stations, and booster pump stations.

### REDUNDANCY

Modulus Cellular Communications modules support redundancy for enhanced reliability. If a module goes off-line, a designated backup can take over automatically.

# Modulus Cellular Communications Module with Audio Out - Type 1120 - Specifications

## FIELD I/O

<b>Discrete Inputs:</b>	1	High-speed, non-isolated DC or contact closure, DC to 20KHz maximum
Input Range:		Contact closure/open collector driver to ground, or 0 to 30Vdc (ON=<1.5V, OFF > 2.5V)
Input Current:		Approximately 0.5mA (internal current source)
Filtering:		Individually configurable: 5Hz, 10Hz, 20Hz, 50Hz, 100Hz, 500Hz, 1KHz, 2KHz, 5KHz, 10KHz+
	4	Optically Isolated, bipolar (AC/DC, not polarity sensitive)
Input Range:		0 to 30V (OFF < 6V, ON>9V)
Input Current:		1.2mA @ 12V, 3mA @ 24V
Filtering:		Individually configurable: 20Hz or 100Hz
<b>Discrete Outputs:</b>	1	Solid-state Protected FET high-side driver (switches to input power when ON)
Output Rating:		30Vdc, 2A maximum, current limited to approximately 2.25A.
<b>Analog Inputs:</b>	2	16-bit, Delta Sigma, individually software configurable ranges
Input Range:		<ul style="list-style-type: none"><li>• [8X-513X] 20mA (minimum input for full accuracy is 0.5mA)</li><li>• [8X-523X] 5V, +/-5V, 10V, +/-10V, 30V</li><li>• [8X-533X] 50K ohms, temperature using 2.2K, 10K (type II, III and w/11.K shunt) thermistors</li></ul>

## COMMUNICATIONS

<b>Ethernet:</b>	1	10/100mb/s (10/100 Base-T)
SCADA Protocols		Modbus TCP & UDP (master/slave), Ethernet IP (master/slave PLC5 & SLC5/05 emulation), SDX (AES-128 Encryption), MQTT, Ethernet to Serial bridging
Internet Protocols		HTTP (server), FTP (server & client), E-mail (SMTP and POP3), ICMP (ping; server & client), NTP (client), DHCP (server & client), DNS, DDNS
<b>Cellular:</b>	1	4G LTE: [8x-5x31] 700(B13)/AWS1700(B4)/1900(B2) (Verizon)
		4G LTE: [8x-5x32] 700(B12/B13)/850(B5)/AWS1700(B4)/1900(B2) (AT&T, T-Mobile, International)
SCADA Protocols		Modbus TCP & UDP (master/slave), MQTT
Internet Protocols		HTTP (server), FTP (server & client), E-mail (SMTP and POP3), ICMP (ping; server and client), DNS, DDNS
<b>Serial:</b>	1	RS-485 Bus port (this port is available for general purpose communications if not used for high-speed bus communications with other modules)
Baud Rates (all ports)		115K, 38.4K, 19.2K, 9600, 4800, 2400, 1200 baud.
Protocols		Modbus RTU (master/slave), DF1 (slave), SDI-12 (general purpose port only)
<b>Audio:</b>	2	18-bit audio outputs, <0.2% Total Harmonic Distortion
File Storage		Dedicated 32MB internal flash disk; up to 1000 audio file segments
File Format		MP3 compressed audio with automatic sample rate detection and playback; 320 kbit/s maximum
Output Levels and Load		1.6Vpp into 30 ohms with electronic programmable attenuation and tone controls

## HMIs

<b>Local:</b>	128x32 graphical, wide temperature range yellow OLED and single pushbutton
<b>Graphical:</b>	Web based, graphic library included. Compatible with most browsers, including Internet Explorer, Firefox, Chrome, Safari, Android
<b>Mobile:</b>	Web based, text only, up to 50 registers. Compatible with most browsers, including Internet Explorer, Firefox, Chrome, Safari, Android

## PROGRAMMING

<b>Languages:</b>	Ladder Logic, Function Block, Text—built-in web based graphical and text editor and debugger
<b>Capacity:</b>	64KB logic, 2MB source code, 32-bit integer and floating point math

## STORAGE

<b>Registers:</b>	504 Numeric registers, 504 Boolean registers
<b>Internal Flash disk:</b>	32MB
<b>Removable disk:</b>	Micro SD Card (up to 256GB, supplied by customer)

## CLOCK

<b>Real Time Clock:</b>	Temperature compensated with lithium battery backup power
Stability	+/- 3ppm from -30°C to 70°C

## GENERAL

<b>Input Power:</b>	10Vdc to 30Vdc
<b>Power Consumption</b>	
Not using Ethernet	68mA @ 12Vdc / 40mA @ 24Vdc (Ethernet power saver enabled)
Using Ethernet	108mA @ 12Vdc / 60mA @ 24Vdc
<b>Field Wiring Termination:</b>	[81-5x3x] screw terminal blocks [82-5x3x] lever terminal blocks, 3.5mm, 22 to 14GA wires
<b>Antenna Connector:</b>	SMA female (female pin center conductor)
<b>Temperature:</b>	-40°C to 70°C (operating), -40°C to 85°C (storage)
<b>Humidity:</b>	<95% RH (non-condensing)
<b>Enclosure:</b>	Polyamide, light gray (RAL 7035)
<b>Mounting:</b>	35mm DIN rail with bus connector block



# Modulus Cellular Communications Module with Audio Out - Type 1120—Antenna Wiring

## DIMENSIONS and CONNECTIONS

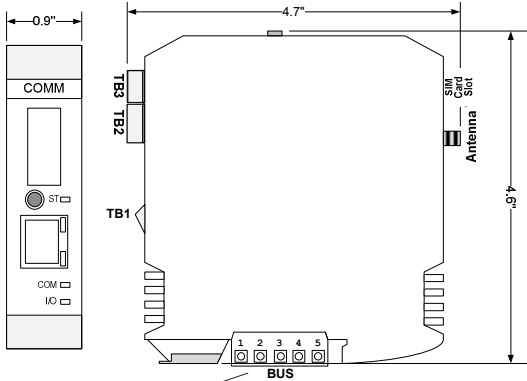

Terminal	Function
1	-485
2	+485
3	RESET#
4	GND
5	+V

Terminals	TB1	TB2	TB3
1	DI1	AUDIO L	DI2
2	AI1	AUDIO R	DI3
3	AI2	PTT	DI4
4	DO1	GND	DI5
5	GND		DIC

## Antenna System Options

Most cellular based systems typically have less costly and complex antenna system requirements. The choice of antenna components depends on the type of enclosure housing the enclosure (metallic or non-metallic) and the proximity to the nearest cellular tower.

### Non-metallic Enclosure

When installed in a non-metallic enclosure, the simplest and lowest cost antenna solution is a whip antenna screwed directly into the SMA antenna connector on the module. The part number is **98-3411**.



### Metallic enclosure—standard.

If the module is installed in a metallic enclosure, many applications can use a low-cost "salt-shaker" style antenna (part number **98-3402**), mounted on the enclosure. The antenna is connected to the communications module with a short internal antenna cable (part number **98-6136**).



"salt shaker" antenna

### Metallic enclosure—difficult reception areas.

Sometimes, the site location may not be close to the carriers cellular tower. This may require a higher performance antenna system using a Yagi directional antenna elevated on a support pole or structure.. You will need to aim the antenna towards the desired cellular tower (the carrier can help you identify the tower location). A lightning arresstor is generally recommended since the antenna is elevated, making it a better "target" for a lightning strike. Use a dedicated grounding rod and bonding as shown for the lightning arresstor.

### Antenna System BOM:

- 98-6136** 36" Internal Antenna Cable
- 98-8011** Lightning Arresstor
- 98-42xx** Low-loss Antenna Cable (xx= length in feet)
- 98-3409** Cellular Yagi Antenna w/ weather radome
- 98-9002** Weatherproofing Kit (for external antennal connections)

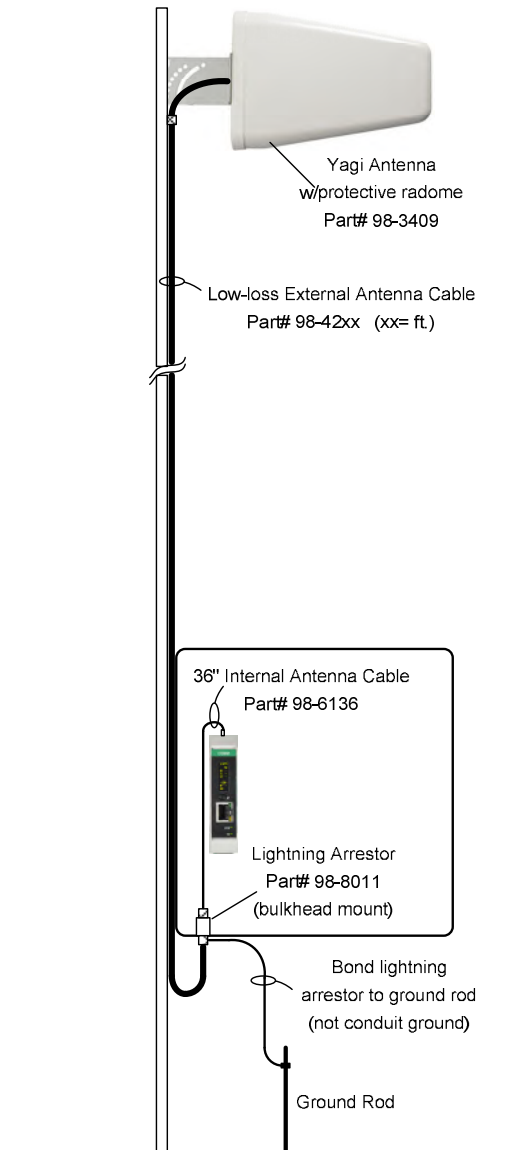

# Modulus Cellular Communications Module with Audio Out - Type 1120 - Field Device Wiring

**!** Refer to the installation manual for additional installation details and precautions.

## Discrete Input DI1, Discrete Output DO1 & Analog Inputs —TB1

The field wiring may be connected directly to the TB1 terminal block, or through a field Wiring Panel as shown in the diagrams below. All discrete inputs/outputs and analog inputs are referenced to the ground terminal (5). This terminal is connected internally to the power supply ground.

The Discrete Input accepts a contact closure or open-collector ("NPN" style) input signal. An external pull-up resistor is not required.

The Discrete Output sources current by switching the module input power to the output terminal.

The 8x-513x models have analog Inputs that accept 20mA current signals. Loop powered (Figure A) and self-powered (Figure C) devices are supported. In power conserving applications, the analog sensors may be powered from the Discrete Output (Figure B), configured to switch power to the sensors only when needed to take an analog reading (with configurable "warmup" time).

The 8x-523x models have analog Inputs that support voltage sensors (+/-5v, +/-10v and 30v) while the 8x-533x models support resistance sensors including thermistor type temperature sensors. The wiring for these sensors is shown in Figure D below.

Note that for loop powered devices, model 82-01xx Field Wiring Panels should be used. For self-powered devices, either model 82-00xx or 82-01xx Field Wiring Panels may be used.

### 8x-513x (20mA Analog Inputs)

**FIGURE A**  
20mA Loop Powered Sensors  
External Loop Supply

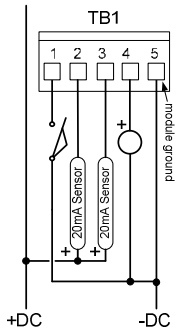

**FIGURE B**  
Sensor Power from  
Discrete Output

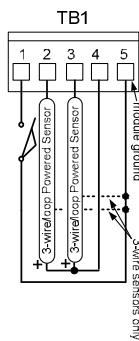

**FIGURE C**  
Self-powered  
20mA Sensors

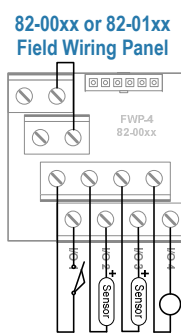
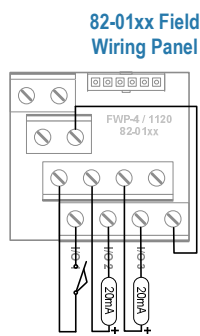
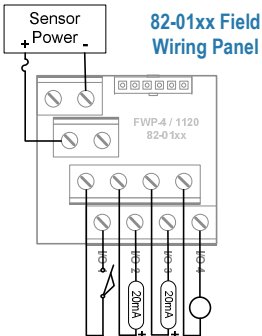
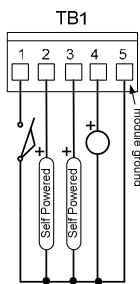

## Audio and Push-to-Talk Outputs—TB2

Audio Out Comm modules add two high-quality audio output channels and a transistor "open collector" Push-to-Talk discrete output to the base module. These can be used to announce audio messages over a public address or audio radio system. The field wiring to these outputs may be connected directly to the TB2 terminal block, or through an 82-02xx Field Wiring Panel as shown in the diagrams below.

The Audio Outputs have both left and right channels, along with a "Push-to-Talk" open collector output that will switch to ground when audio is playing. This can be used to activate the output of a public address amplifier, or key an audio radio transmission when audio is being played.

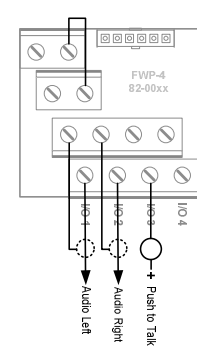
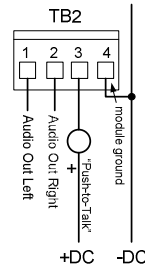

## Discrete Inputs DI2 to DI5 —TB3

Audio Out Comm modules have four optically isolated discrete inputs. The field wiring to these inputs may be connected directly to the TB3 terminal block, or through a Field Wiring Panel as shown in the diagrams below. The common for the discrete inputs is shared among the four inputs but isolated from the rest of the module.

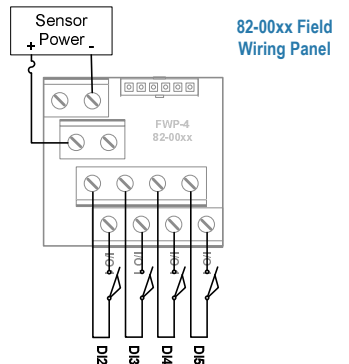
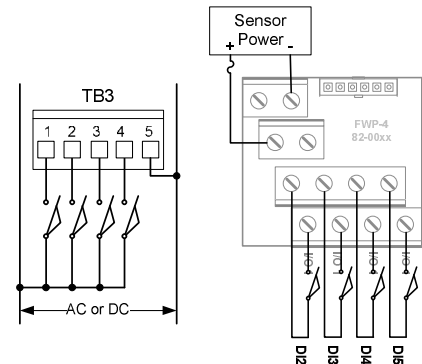

Sensor power may be AC or DC of either polarity. It can be the same source as the module input power.

## 8x-523x (Voltage) and 8x-533x (Resistance/Temperature) Analog Inputs

**FIGURE D**  
Voltage and Resistance  
Sensor Wiring

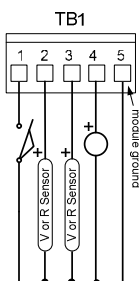

Note:  
Resistance sensors  
do not have a polarity

**82-00xx or 82-01xx  
Field Wiring Panel**

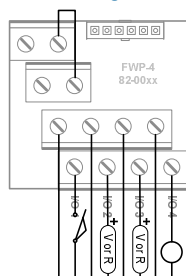





Industrial Control Links, Inc.  
Roseville, CA 530.888.1800